

일반댐퍼



타공치수	250 x 250mm (±5mm)
연결덕트	Ø100

제로크 (舊자이온) (HV-220) (고풍량) (상업용)

- 고정압 저소음
- 중력식 댐퍼

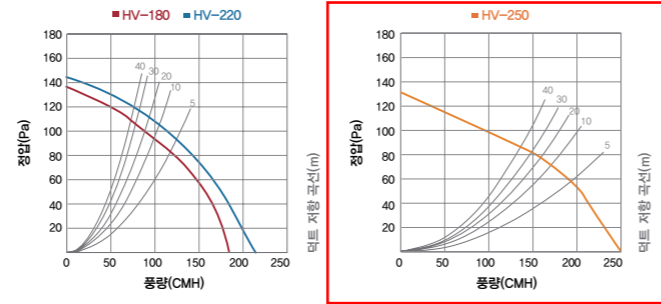

그릴



기본 그릴
320(W) X 320(D)

상세정보

※ 제품의 규격 및 성능은 품질 향상 또는 설치 상황에 따라 변경될 수 있습니다.

모델	HV-220
풍량(CMH)	220
소비전력(W)	33
소음(dB)	40
제품크기(mm)	320(W) X 320(D) X 180(H)
중량(kg)	2.7
전원	1Ø / 220V / 60Hz
선택옵션	전원램프(L)

댐퍼(옵션)

회전형 전동댐퍼



<MD>

제품 치수

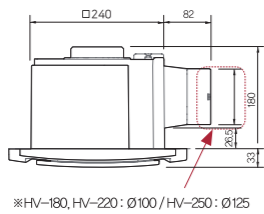

※HV-180, HV-220 : Ø100 / HV-250 : Ø125

제품 설치방법

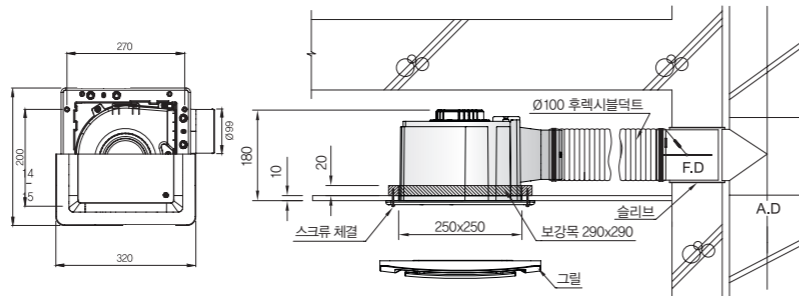

※주의사항: 보강목 두께를 20mm이하로 설치하십시오.



중정압

일반댐퍼



타공치수	165 x 165mm (±5mm)
연결덕트	Ø100

플렉스 (C2-100) (C2-100 LF(MD) (중정압)

- 저소음
- 중력식 댐퍼

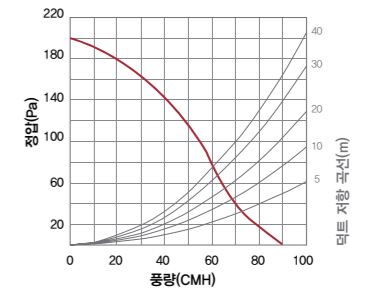

그릴



M 그릴
205(W) X 205(D)



F 그릴
205(W) X 205(D)



L 그릴(화이트)
212(W) X 212(D)

상세정보

※ 제품의 규격 및 성능은 품질 향상 또는 설치 상황에 따라 변경될 수 있습니다.

모델	C2-100	C2-100 LF(MD)
풍량(CMH)	90	90
소비전력(W)	22	22
소음(dB)	38	38
제품크기(mm)	205(W) X 205(D) X 160(H)	205(W) X 205(D) X 160(H)
중량(kg)	1.4	1.4
전원	1Ø / 220V / 60Hz	1Ø / 220V / 60Hz
선택옵션	전원램프(L), 전동댐퍼 [M그릴, F그릴, L그릴]	전원램프(L) [F그릴만 해당]

댐퍼(옵션)

회전형 전동댐퍼



<MD>



제품 치수

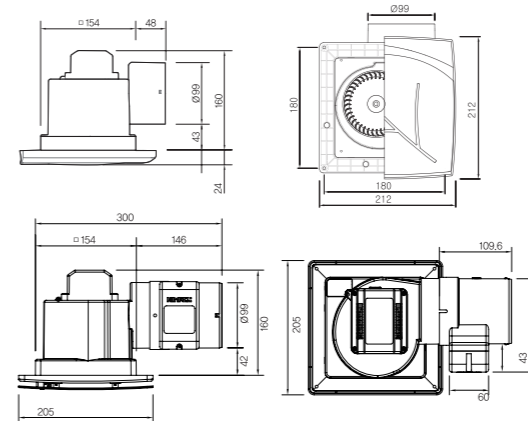

제품 설치방법

